

Kettle Whirlpool Kit

Adjustable Whirlpool Fitting and Valve

Operation, Assembly & Maintenance Manual

Congratulations on your purchase, and thank you for selecting the Whirlpool Kit from Blichmann Engineering™. We are confident that it will provide you years of service and many gallons of outstanding beer. This manual will familiarize you with the assembly, installation procedures, and use of the Whirlpool.

**** PLEASE READ THOROUGHLY PRIOR TO USE FOR IMPORTANT SAFETY INFORMATION ****

Assembly & Installation:

Caution: Prior to installing the Whirlpool, select a position on the kettle that is located near the center of the wort volume and clear from any accessories mounted to the kettle. Be sure the assembled whirlpool will not interfere with heating elements, dip tubes, kettle strainers, thermometers, or any other accessory. Also consider the location of the hose that will connect to the valve. Ensure that the kettle will function properly in the brewery after the whirlpool fitting is installed and a hose is connected to the valve.

Parts List: (All Configurations Shown)

Whirlpool with Linear Flow Valve: (Fig. 1)

1. Linear Flow Valve
2. Bulk Head Fitting
3. Whirlpool Tube
4. Shaft Collar
5. O-ring, -119
6. O-ring, -112
7. Allen wrench 9/64"

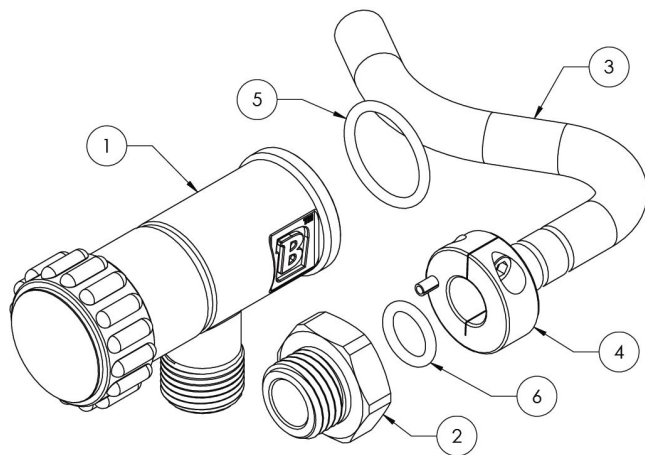

Whirlpool with 1.5" Butterfly Valve: (Fig 3)

1. 1.5" Butterfly Valve
2. 1-1/2" Tri Clamp
3. 1-1/2" Triclamp to 1/2" NPT w/O-ring-groove
4. Bulk Head Fitting
5. Whirlpool Tube
6. O-ring, -119
7. O-ring, -112
8. 1" Tri-Clamp Gasket
9. Shaft Collar
10. Allen wrench 9/64"

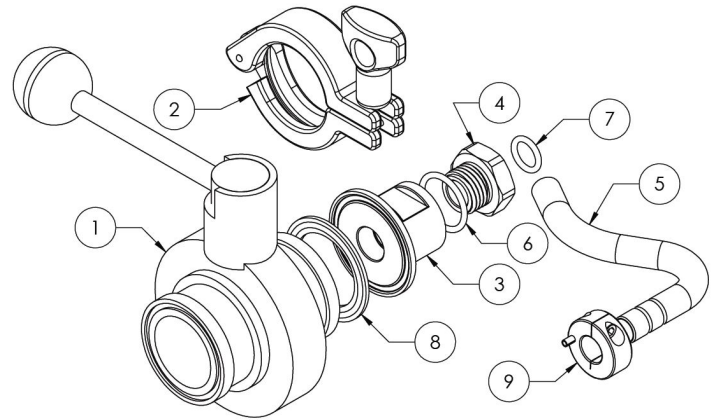

Step One:

The Whirlpool Kit can be installed in kettles with a wall thickness up to 3/16" (4.7mm) thick. Determine the desired location for the Whirlpool and mark the center point with a permanent marker. Ensure this is where you would like to install the assembled whirlpool fitting. Check again to make sure this is exactly where you want to permanently drill a hole into your kettle. Use a center punch on the mark to punch a small divot into the kettle. Drill a 3/16" (5mm) pilot hole, then enlarge it to 13/16" (20.64mm) using a "step drill" as shown in **Fig. 4**. Be sure not to drill too large of a hole with the step drill. Step drills are available through many hardware stores. After the hole is drilled, ensure both sides of the hole are free from burrs. The step drill can be used on the back side of the hole to remove burrs and sharp edges.

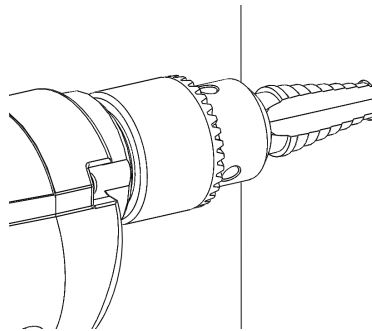

Fig. 4

Step Two:

Insert the bulkhead fitting from the inside of the kettle so the threads protrude to the outside as shown in **Fig. 5**. Teflon tape is **not** used on this fitting or any of parts that mate to this nut.

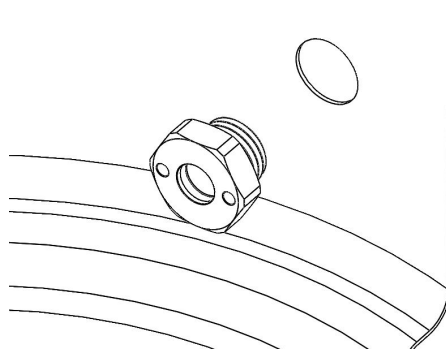

Fig. 5

(The next installation steps will be model specific. Please find the your valve type below)

Linear Flow Valve:

Step Three:

Place the large o-ring in the groove on the face of the Linear Flow Valve as shown in **Fig. 6**. Turn the bulkhead fitting to thread it into the valve. Ensure that the o-ring does not fall out of the groove when tightening. When hand tight, use a wrench on the flats of the valve and a socket and torque wrench on the bulkhead fitting to tighten to 40 ft-lb (54 N-m).

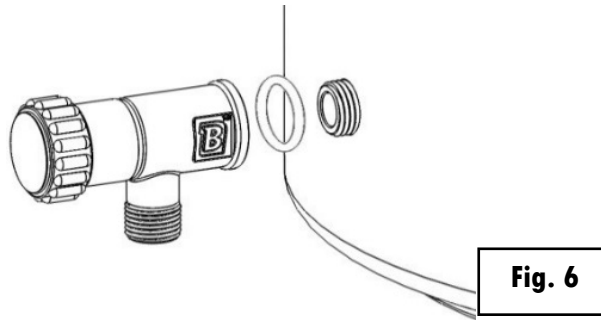

Sanitary Butterfly Valve:

Step Three:

Place the o-ring in the groove on the face of the Sanitary Fitting as shown in **Fig. 8**. Turn the bulkhead fitting to thread it into the Sanitary Fitting. Ensure that the o-ring does not fall out of the groove when tightening. When hand tight, use a wrench on the flats of the Sanitary Fitting and a socket and torque wrench on the bulkhead fitting to tighten to 40 ft-lb (54 N-m).

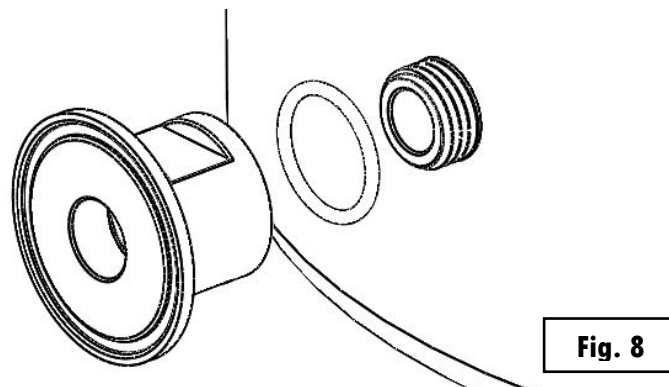

Whirlpool Tube Installation: (All Models)

Step Four:

Ensure the allen screw on the shaft collar is loose. Insert the whirlpool fitting into the shaft collar as shown in **Fig. 9**. The two o-ring grooves (detents) on the tube are used to match your particular kettle diameter. The whirlpool tube will fall into these detents upon insertion into the bulkhead nut. To prevent contact of the tube and the inside of a smaller kettle, use detent **position A**. Use detent **position B** for larger kettles (typically, 10 gallons and up).

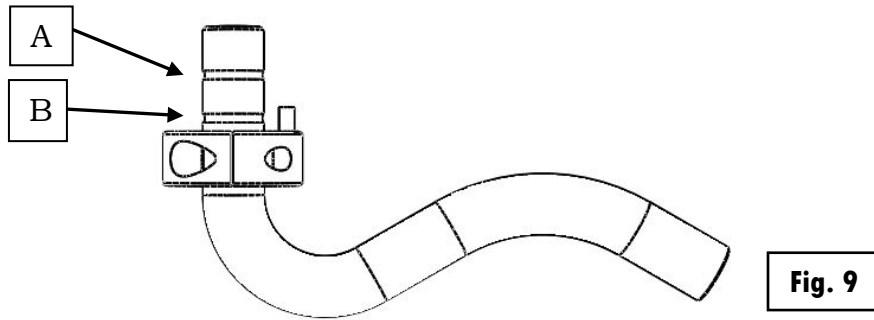

Step Five:

Insert the fitting and collar assembly into the kettle using the desired detent position. Rotate the collar until the pin is aligned with a hole in the bulkhead nut. Rotate the whirlpool fitting to a horizontal position towards the desired whirlpool direction. Hold the collar against the nut and tighten the screw to secure the collar to the fitting, as shown in **Fig 10**.

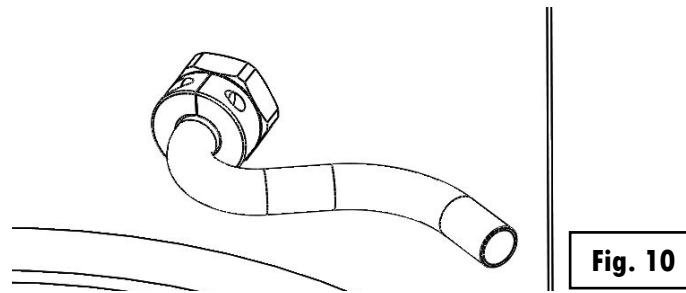

Linear Flow Valve Operation:

The valve can be reoriented by loosening the internal bulkhead fitting while securing the Linear Flow Valve with a wrench. Once loosened, rotate the Linear Flow Valve to the desired position, and re-tighten. Always ensure Linear Flow Valve is tightened prior to use.

Note: This Linear Flow Valve has three positions and provides intuitive feedback to the user.

1. Turned fully clockwise the valve will hit a hard stop. This is the closed position
2. Valve is fully open after three full counter-clockwise turns from the closed position. The thread on the valve body is just visible when fully open. Between closed and fully open is the linear flow range.
3. Disassembly must only be done with an empty kettle. Rotate counter-clockwise until the threads disengage. A slight tug will move the stem into an O-ring detent indicating the stem is ready for removal. Again, confirm the kettle is empty before removing the stem of the Linear Flow Valve.

Warning: STOP turning when you begin to see the threads when draining kettle. Continuing to open the valve will not increase the flow and can result in an unintended release of hot liquid, causing severe burns!

Maintenance:

Immediately after use clean the Linear Flow Valve with hot water and Five Star Chemical's Powdered Brewery Wash or similar detergent and a scrub brush or ScotchBrite™ scouring pad to remove any heavy soil deposits.

Do not use any cleaners containing bleach which is harmful to stainless steel. In addition, DO NOT soak your kettle in cleaners or sanitizers for extended periods (1 hr max) to avoid any problems with pitting or galvanic corrosion. Dry thoroughly after cleaning.

Before and after each use, inspect the Linear Flow Valve for wear or damage. If any of the Linear Flow Valve components show signs of wear or damage discontinue use and contact your Blichmann Engineering™ authorized retailer for replacement parts, part number BE-000504-00.

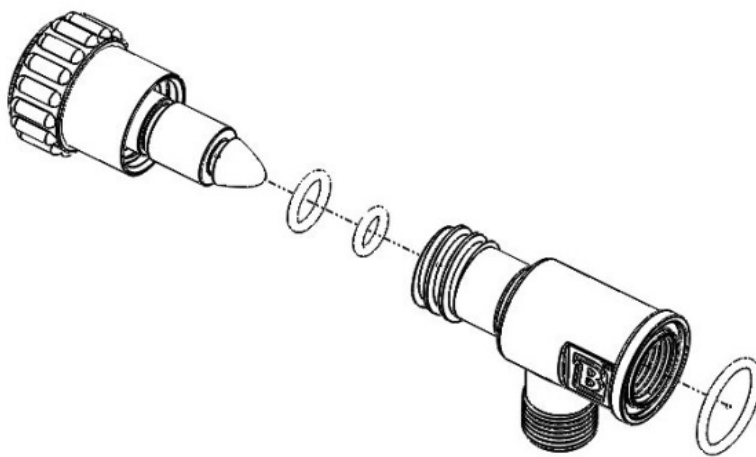

Fig. 11

Whirlpool Operation and tips:

Important: Do not continuously recirculate wort through any item that may accumulate hop particles and other brewing debris. Kettle strainers, screens, and plate chillers may clog due to excessive particle build-up and will slow down or stop proper function of the whirlpool.

- A pump, hose fittings, and high temperature hose (as shown in **Fig 12.**) are required to complete a whirlpool system. Figure 11 shows a typical system setup for a whirlpool. The wort is drawn out of the kettle at position **A**, with the brewing pump in position **B**, and sent to the whirlpool valve at location **C**.

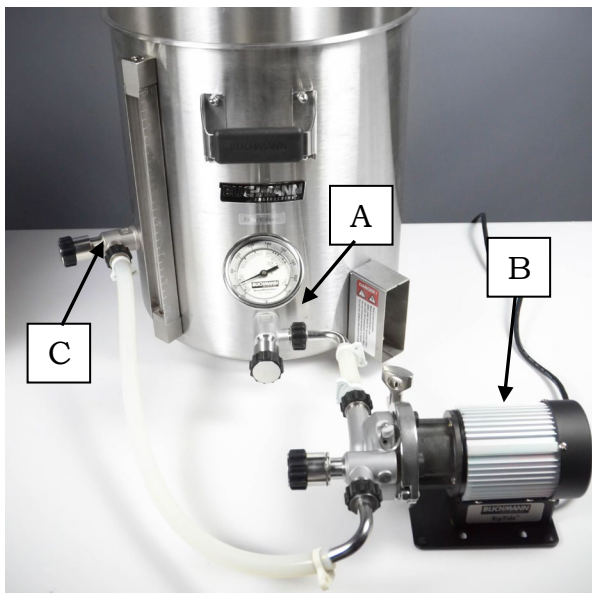

Fig. 12

- A whirlpool is done in a brew-house for several reasons. The main reason is to separate the trub and hot break that builds up during the boil to clarify the wort.
- After pumping from the kettle and back into the whirlpool for several minutes, a cone of hops, hot break, and other solids will form in the bottom of the kettle and the wort will be clearer than before.
- The following are few traditional ways that a whirlpool can be used:
 1. With a cooling coil (immersion chiller) submerged in the wort to increase the heat transfer rate and chill faster
 2. With an immersion chiller to lower the temperature and hold. Below 180°F, hops can be added to contribute to aroma without increasing bitterness but it's not until below 140°F, the production of DMS has stopped.
 3. Without any chilling method to clarify the wort and increase hop isomerization
 4. An alternative port in the kettle to fill, drain, or sample wort.
- We recommend that the pump, hoses, and fittings are cleaned and sanitized prior to whirlpooling
- Whirlpool for about 5 minutes, or until maximum rotation of the wort is achieved and let stand for 15-20 minutes to let the convection currents to stop and the solids settle to the bottom of kettle.
- Clean all components immediately after use with Five Star Chemical's Powdered Brewery Wash, rinse well and let dry.

Blichmann Engineering Product Warranty

A. Limited Warranty

1. Blichmann Engineering warrants to the original purchaser that this product will be free from manufacturing defects in material and workmanship for a period of one (1) year from the date of purchase by the customer. Proof of purchase is required. Blichmann Engineering's obligation to repair or replace defective materials or workmanship is the sole obligation of Blichmann Engineering under this limited warranty.
 2. This product is for home use only. The limited warranty covers only those defects that arise as a result of normal use of the product and does not cover any other problems, including, but not limited to, those that arise as a result of:
 - a. *Improper maintenance or modification;*
 - b. *Damage due to incorrect voltage or improper wiring by customer;*
 - c. *Operation outside of the product's specifications;*
 - d. *Carelessness or neglect to operate the product in accordance with instructions provided with the product;*
 - e. *Damaging the tamper label on the product;*
 - f. *Damage by over-tightening the fasteners;*
 - g. *Failure to follow cleaning and / or maintenance procedures; or*
 - h. *Exceeding published operational temperatures.*
 3. Blichmann Engineering reserves the right to request delivery of the defective component for inspection before processing the warranty claim. If Blichmann Engineering receives, during the applicable warranty period, notice of a defect in any component that is covered by the warranty, Blichmann Engineering shall either repair or replace the defective component with a new or rebuilt component at Blichmann Engineering's option.
 4. Blichmann Engineering must be notified within seven (7) days of the delivery date of any shipping damage. Customer is responsible for shipping damage outside of this time period. Approval for return must be provided by Blichmann Engineering prior to any return. Customer is responsible for keeping all original packaging material for warranty returns. Blichmann Engineering is not responsible for damage from improperly packaged warranty returns, and these repair costs will be the sole responsibility of the customer. Shipping costs for warrantee returns are covered only for the contiguous United States.
 5. Blichmann Engineering's limited warranty is valid in any country where the product is distributed.
-

B. Limitations of Warranty

1. Any implied warranty that is found to arise by way of state or federal law, including any implied warranty of merchantability or any implied warranty of fitness, is limited in duration to the terms of this limited warranty and is limited in scope of coverage to this warranty. Blichmann Engineering disclaims any express or implied warranty, including any implied warranty of fitness for a particular purpose or merchantability, on items excluded from coverage as set forth in this limited warranty.
 2. Blichmann Engineering makes no warranty of any nature beyond that contained in this limited warranty. No one has authority to enlarge, amend, or modify this limited warranty, and Blichmann Engineering does not authorize anyone to create any other obligation for it regarding this product.
 3. Blichmann Engineering is not responsible for any representation, promise, or warranty made by any independent dealer or other person beyond what is expressly stated in this limited warranty. Any selling or servicing dealer is not Blichmann Engineering's agent, but an independent entity.
-

C. Limitations of Liability

1. The remedies provided in this warranty are the customer's sole and exclusive remedies.
 2. Except for the obligations specifically set forth in this warranty, in no event shall Blichmann Engineering be liable for direct, indirect, special, incidental, or consequential damages, whether based on contract, tort, or any other legal theory and whether or not advised of the possibility of such damages.
 3. This warranty does not cover, and in no event shall Blichmann Engineering be liable for, travel, lodging, or any other expense incurred due to manufacturing defects in material and workmanship, or any other reason.
 4. Any performance of repairs after the warranty coverage period has expired or performance of repairs regarding anything excluded from coverage after this limited warranty shall be considered good-will repairs and they will not alter the terms of this limited warranty, or extend any warranty coverage period.
 5. Venue for any legal proceedings relating to or arising out of this warranty shall be in Tippecanoe County, Indiana, United States, which courts will have exclusive jurisdiction.
-

D. Local Law

1. This warranty gives the customer specific legal rights. The customer may also have other rights that vary from state to state in the United States or other countries.
2. To the extent that this warranty is inconsistent with local law, it shall be deemed modified, only to the extent necessary to be consistent with such local law.